

Very Low-Noise Unconditionally Stable MMIC Amplifiers *for VHF & Up*

Paul Wade W1GHZ ©2024 updated 7/10/2024

w1ghz@arrl.net

Some of us may remember when a preamp involved finding an exotic device, building a circuit, tuning until the Johanson trimmers wore out, and having it oscillate if a bird flew by. All for a 3 dB Noise Figure.

There are several MMICs available that provide very low noise figures for VHF to low microwave frequencies, with no tuning needed. One problem with these broadband amplifiers is that they also amplify out-of-band signals, which can create IMD which may make the signal-to-noise ratio worse rather than better.

For instance, on 222 MHz at my QTH, the apparent noise floor rises more than 10 dB in certain directions. A PGA-103 MMIC preamp improves the signal-to-noise ratio (SNR) in quiet directions, but does not help in the noisy directions. I use an SDR panoramic display to judge the SNR on a weak beacon signal – the noise floor is the baseline level. Adding a good bandpass filter before the preamp improved things in all directions, even though it has about 1 dB loss; the noise floor now only rises about 3 dB in the worst direction, a tolerable situation. However, when I tried a sharper bandpass filter, the preamp seemed to oscillate, with no weak signals getting through.

The PGA-103 MMIC preamps measured very good noise figure from 2 meters up to 1296 MHz at conference measurements, but occasionally acted strangely in various setups, suggesting possible stability problems.

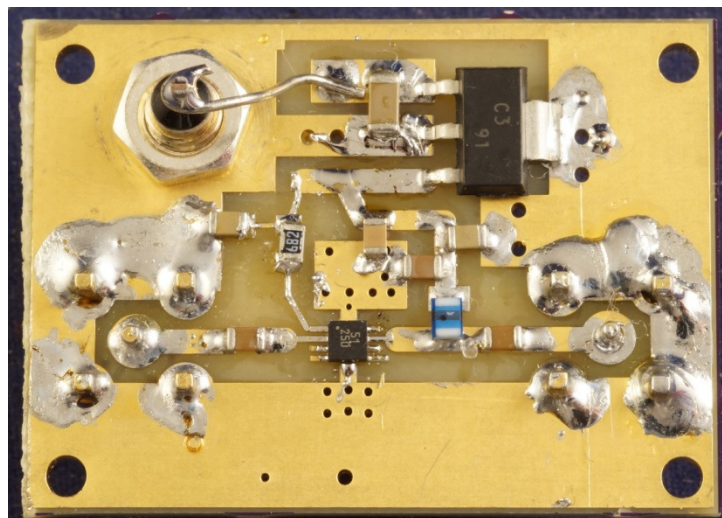

Figure 1 – Unconditionally stable MMIC LNA

Unconditionally Stable MMIC

I am always on the lookout for useful new MMICs and equipment. Don, W1FKF, frequently finds some interesting stuff that I can't resist! Recently, while preparing a Mouser parts order, I came across a new MMIC from NXP, the BGU8051, described as a low noise high linearity amplifier from 0.3 to 1.5 GHz. Specs state unconditionally stable, $K > 1$, up to 20 GHz and NF of 0.43 dB at 900 MHz. The price is about \$3, so I ordered a few to try.

The problem with this MMIC, and many other great-sounding new devices, is the tiny package, a 2mm square SMT package with no leads, only small pads, and a central ground pad underneath. I designed a test PC board and sent it off to OshPark.com – they charge by the square inch, so small PC boards are very economical.

When the board came back, I found that I had gotten the MMIC footprint backwards; the reversed input and output were manageable, but the bias pin was shorted, so it couldn't work. But it was usable to see if I could solder the tiny package. I tried with a hot-air tool but only managed to blow it away. Mike, N1JEZ, came to the rescue – he has calibrated a toaster oven as a soldering oven for SMT assembly¹. Mike was able to solder a couple of parts to the PC boards, so I fixed the PC layout and ordered more boards.

Mike soldered parts to the new boards, and they drew current as expected, so I assembled one to test, shown in Figure 1. You can see that the MMIC is about the same size as the 0805 chip capacitors.

The schematic diagram in Figure 2 is very simple. The bias resistor, R1, sets the device current. Data sheet values show L1 as 33 nH, and C1,2,&3 are 100 pf. Larger values might be better for VHF frequencies.

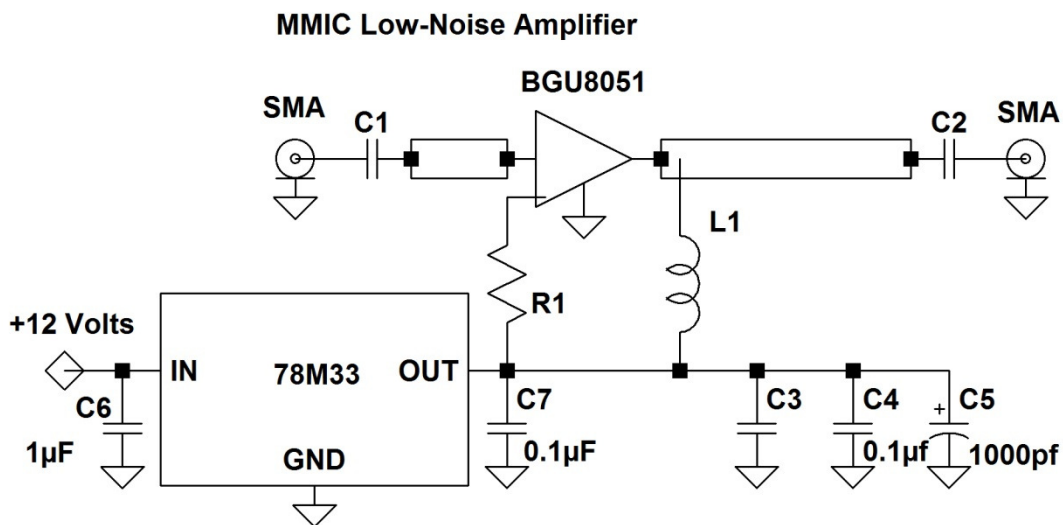

Figure 2 – Schematic diagram of BGU8051 LNA

A quick test with recommended $R1 = 5.1K$ showed good gain and a noise figure of 1 dB or lower at both 144 and 1296 MHz (I don't trust my NF numbers below 1 dB). To look for best NF, $R1$ was replaced with a variable resistor and supply voltage varied from 3 to 5 volts. The sweet spot seemed to be at 3.3 volts and current between 16 and 25 ma ($R1$ 6 to 8K), improving the NF by about 0.2 dB. The final assembly added the 3.3 volt regulator and a 6.8K resistor. I didn't have a 33nh inductor, so I used 47nh.

The amplifier gain, measured with a NanoVNA and a 30 dB attenuator to avoid overload, is shown in Figure 3. Gain is more than 20 dB at 144 MHz and about 15 dB at 1296 MHz, with some gain up to at least 3 GHz. The input return loss, the inverse of S_{11} shown in Figure 3, is very poor below 500 MHz, suggesting that VHF noise figure might be improved with some tuning. This will be investigated when more are assembled.

29 Feb 2024

BGU8051 Preamp
3.3 Volts, 6.8K bias
100pf, 47 nh

W1GHZ

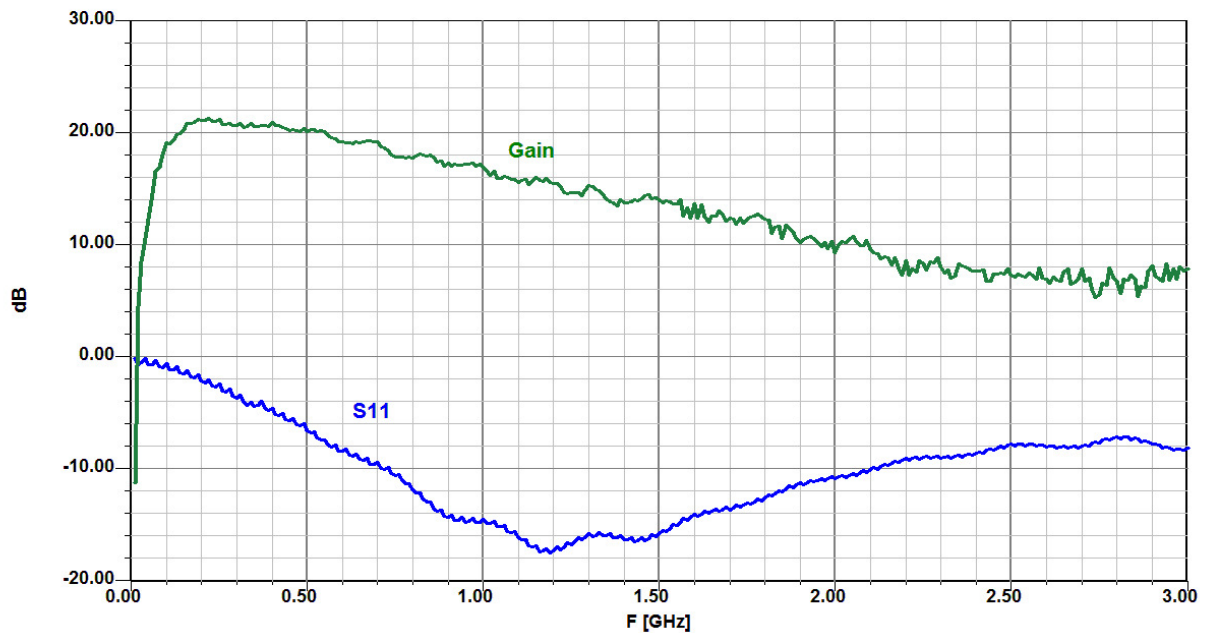

Figure 3 – Performance of BGU8051 Preamp Prototype

Unconditional Stability

To be at all stable, an amplifier must have more isolation in the reverse direction than gain in the forward direction. Unconditional stability is a more complex calculation requiring magnitude and phase of all four S-parameters – we will assume that the manufacturers did this correctly. With my nanoVNA, I measured the magnitudes of all four S-parameters, shown in Figure 4. The isolation, S_{12} , is larger than the gain, S_{21} , up to 6 GHz – above that, there is no gain. Of course, poor layout can provide feedback and compromise stability.

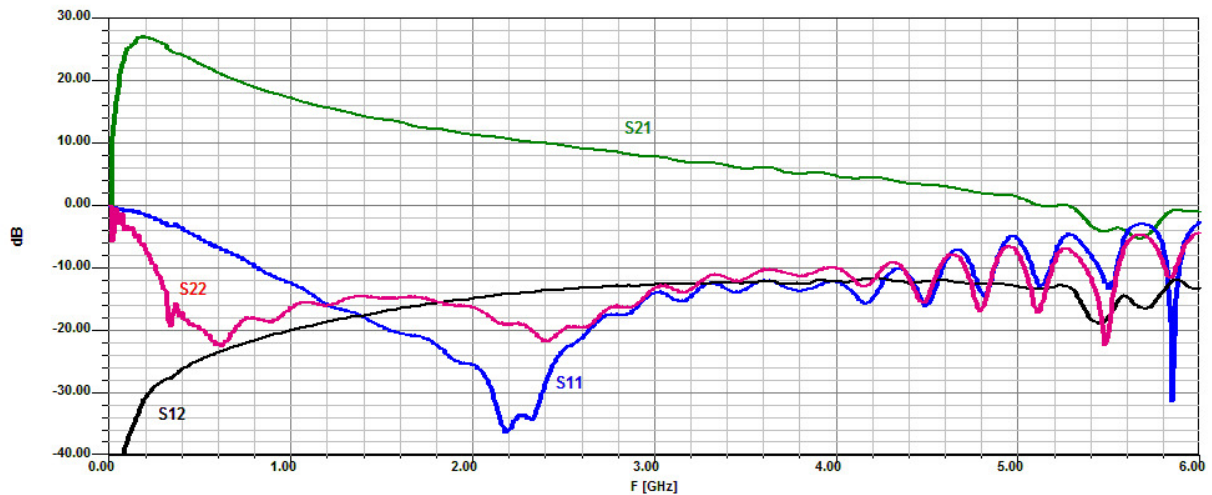

Figure 4 – All Four S-Parameters of BGU8051, showing probable stability

Other Unconditionally Stable MMICs

Poking around a bit more at Mouser.com found some other promising candidates from Qorvo: the QPL9547, the TQP3M9036, and the TQP3M9037. I then searched on ebay to see if any of these devices were available in assembled PC boards from our friends in the far east, and found the module shown in Figure 4, for about \$25 from a USA shipping vendor.

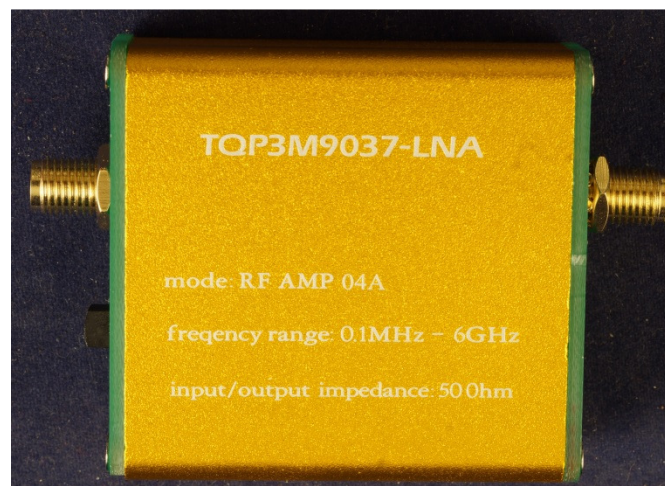

Figure 5 – TQP3M9037-LNA module found on ebay

The module is powered by a USB-C port, making testing easy. A quick check showed noise figure similar to the BGU8051. Putting it on the nanoVNA, Figure 5, showed more gain and better VHF input match. The gain is pretty good to at least 3 GHz – it says 6 GHz on the cover.

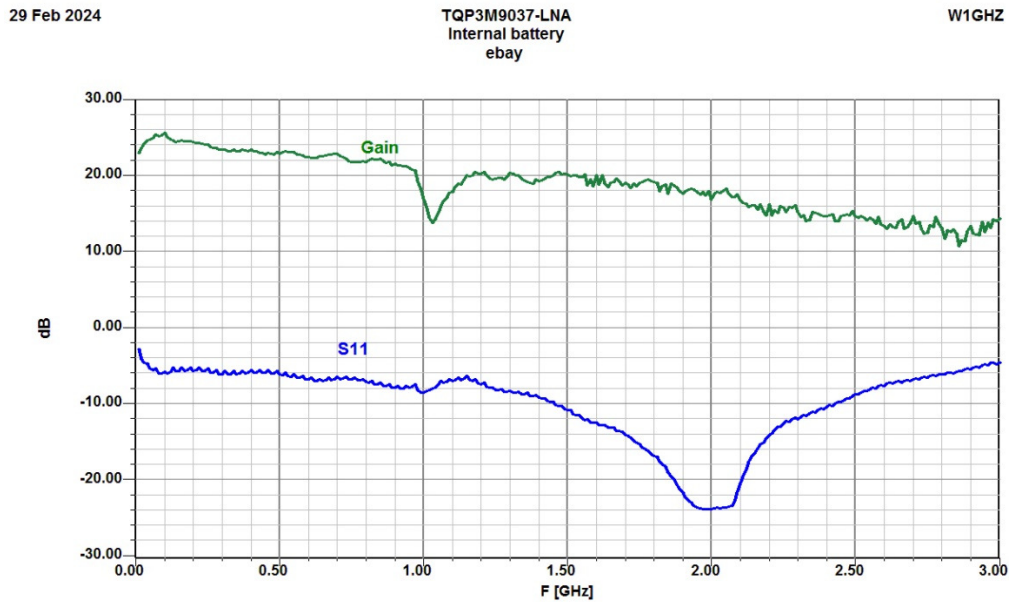

Figure 6 – Performance of TQP3M9037-LNA module

When I opened it up (Figure 6), I found an internal battery and more stuff on the PC board than my simple amplifier. The capacitors and RF choke are much higher value, enhancing VHF performance. There appear to be protective diodes at the input and a provision for powering the amplifier through the output connector.

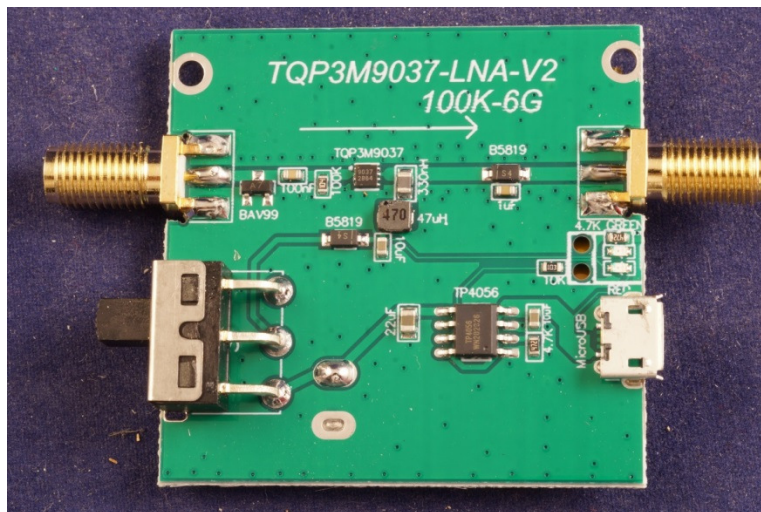

Figure 7 – PC board inside TQP3M9037-LNA module

More Preamps with the other devices

Since the data sheets for the Qorvo QPL9547, TQP3M9036, and TQP3M9037 looked promising, I ordered a few of each, as well as more BGU8051 and more PC boards. Mike, N1JEZ, assembled them all with his toaster oven, with 100% yield – great work. Then I added the passive components and voltage regulator. The QPL9547 uses a bias resistor like the BGU 8051; I experimented with it and found best NF around 3.3 volts and 3.3K resistor. The TQP3M9036 and TQP3M9037 don't need a bias resistor, simplifying assembly; they also seemed to prefer around 3.3 volts, so I used 3.3 volt regulators on all except one. I forgot on that one and put 12 volts on the MMIC, letting out the magic smoke. With a couple of exceptions to try different component values, all of them have 100 pf RF capacitors and 33 nh RF chokes, plus low-frequency decoupling.

I also assembled some with edge mounted SMA connectors and others with through the board SMA connectors. Figures 8 and 9 show four of each, one device in each configuration.

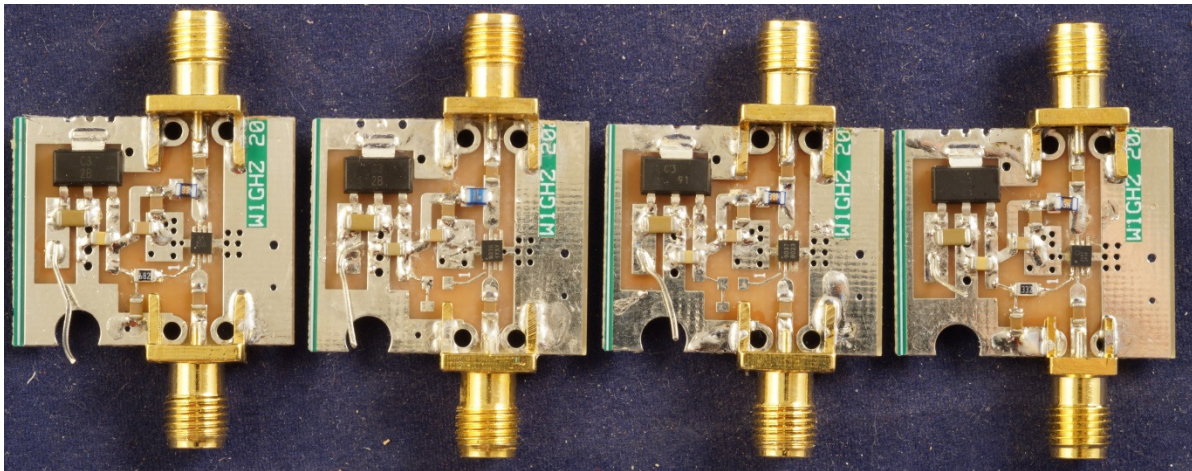

Figure 8 – One of each device type with edge SMA connectors

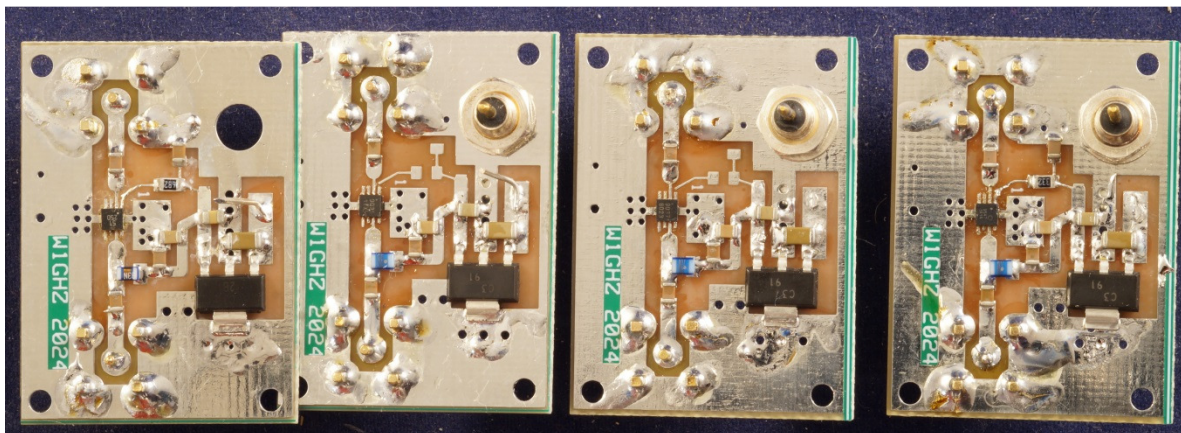

Figure 9 – One of each device type with thru-hole SMA connectors

Noise Figure

I wanted to get better Noise Figure numbers, so I dug out a couple of good preamps that had previous NF measurements – one, from AD6IW, had measured ~0.4 dB NF at 144, 432, and 1296 MHz. At each frequency, I set my AIL7514 to match the previous data, then measured all the preamps.

All the preamps were very good, less than 0.4 dB at 144 MHz, less than 0.5 dB at 432 MHz, and 0.5 dB or lower at 1296 MHz – some quite a bit lower. The analog NF meter doesn't have enough resolution to sort out nits, so I made more measurements at the 47th Eastern VHF/UHF/Microwave Conference.

Thanks to Greg Bonaguide, WA1VUG, of Rohde & Schwarz, I was able to get good measurements on a number of these low-noise devices using an R&S FPL1026 Spectrum Analyzer with NoiseCom NC346A PREC noise source. In Figure 10, the BGU8051 amplifiers are very good; measured noise figures up to 432 MHz were below 0.4 dB, as expected. At 902 and 1296 MHz, they are still pretty good, but not as low as expected from measured at home. At higher frequencies, the NF is higher and the gain fails off.

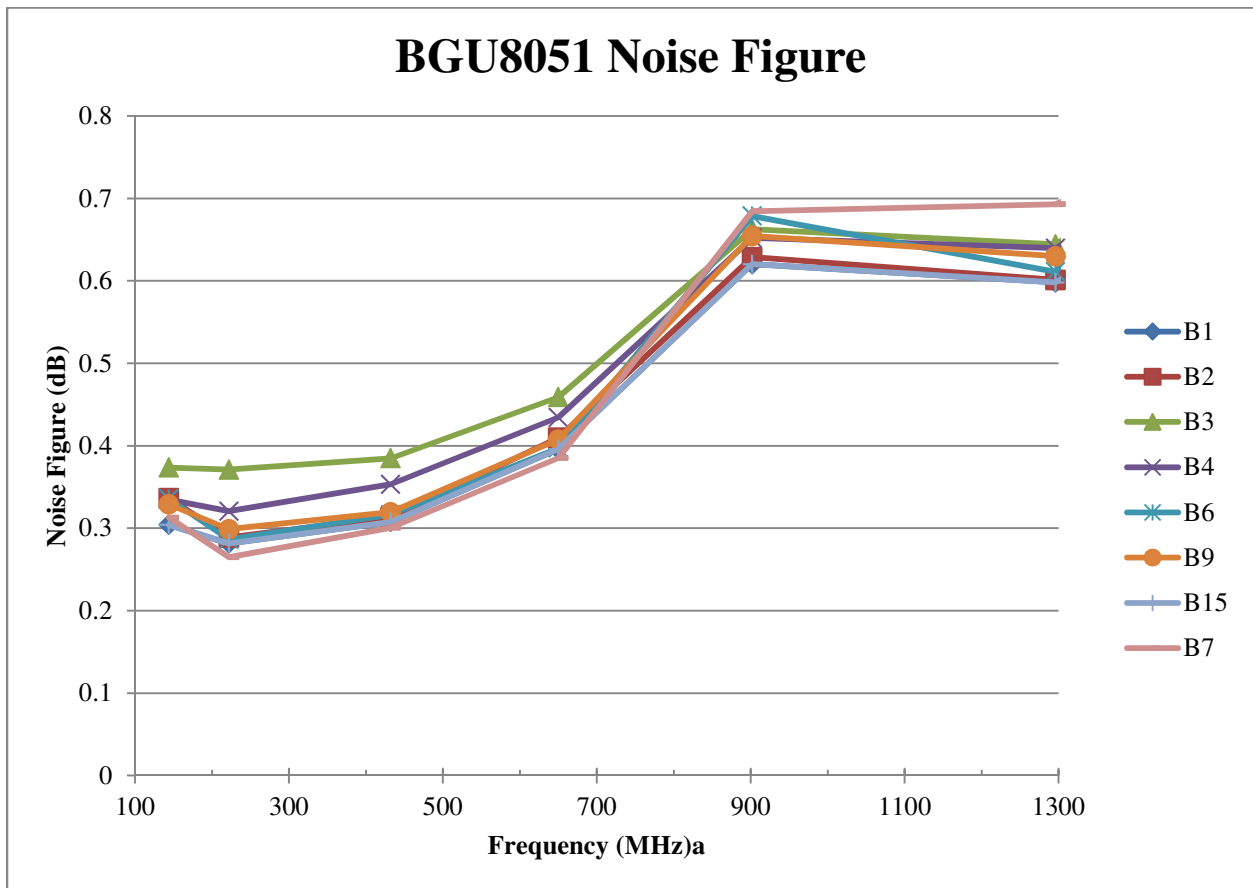

Figure 10 – Noise Figures of eight BGU8051 LNAs.

Noise Figures for the other three devices, the Qorvo QPL9547, TQP3M9036, and TQP3M9037, were similarly low at VHF and UHF. I only had a few samples of each so a representative of each type is shown. At higher frequencies, all three types had higher gain and better NF, under one dB at 2.3 or 2.4 GHz, and under 1.5 dB at 3.4 GHz. At 5.76 GHz, NF is significantly higher and gain, less than 10 dB, is too low to be really usable.

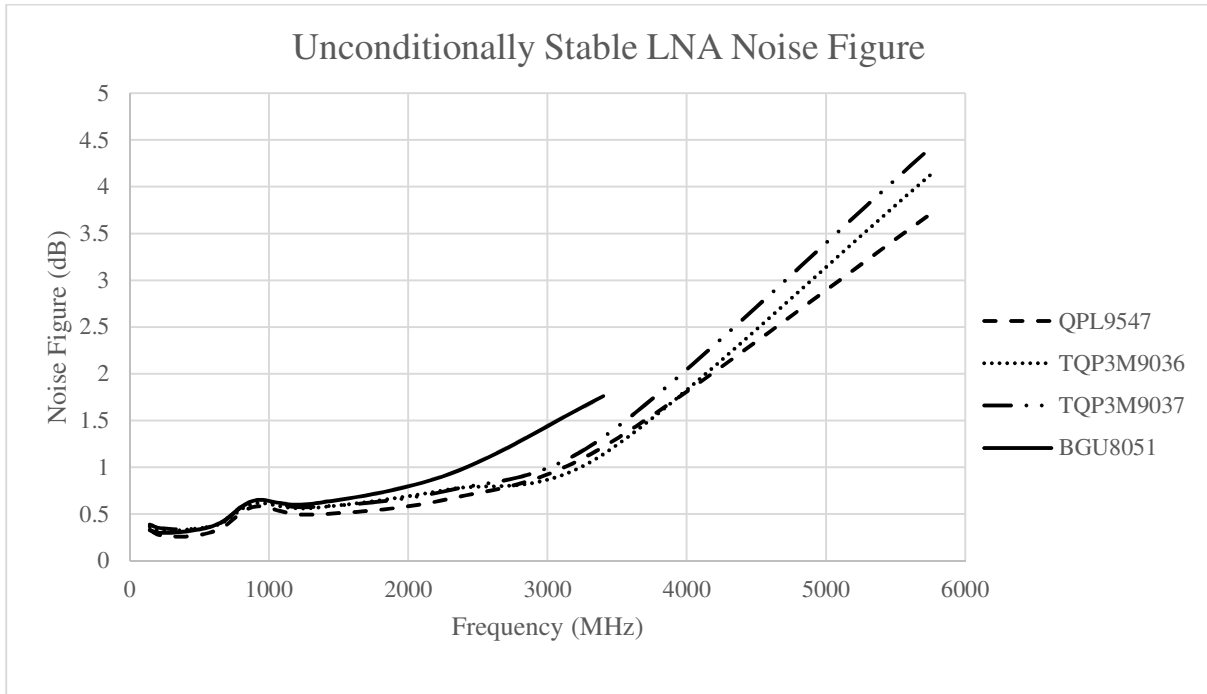

Figure 11 – Comparison of Unconditionally Stable LNA Devices

Noise Figure Calibration

At various conferences, I have acquired a half-dozen very low noise LNA for future EME use (still working on it). These all have the original data from the hams who built them, so I measured them for comparison, and found that my measurements were slightly higher:

- 144 & 432 MHz < 0.1 dB difference
- 902 MHz 0.23 to 0.25 dB higher
- 1296 MHz 0.04 to 0.17 dB higher
- 2304 MHz 0.18 to 0.27 dB higher

Gains are very close.

Assuming that the R&S instrument has traceable calibration, we can conclude that Figures 10 and 11 are on the conservative side. Use any fudge factor you prefer.

Gain & Return Loss

Gain and input Return Loss was measured with a nanoVNA. Since the nanoVNA output is a fairly large signal and the return port is limited to about 0 dBm, I had to add a 30 dB attenuator at the input of the amplifiers to measure gain, and move the attenuator to the output to measure S11 (Return Loss with negative sign). The measured attenuation is added to the measured gain in software.

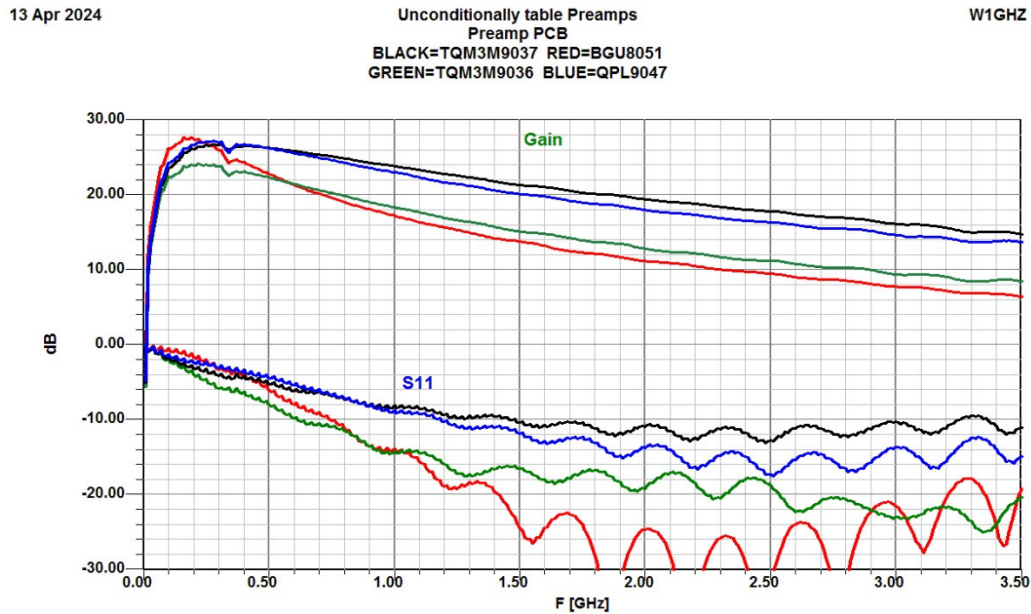

Figure 12 – Comparison of the four device types

Component Values

The default component values 100 pf and 33 nh, are apparently for 900 or 1900 MHz test. I tried other values on a few devices to see the effect at lower frequencies, with results shown in Figure 11. Larger component values increase low frequency gain and make the higher frequency input match worse; they also make the NF at 1296 MHz a bit worse.

The bias resistor R1 can also be varied for best noise figure. At 3.3 volts, I found the best NF with roughly 6.8K for the BGU8051 and 3.3K for the QPL9547, but I didn't fine tune it for each amplifier. The TQM3M9036 and TQM3M9036 don't use a bias resistor, simplifying assembly slightly

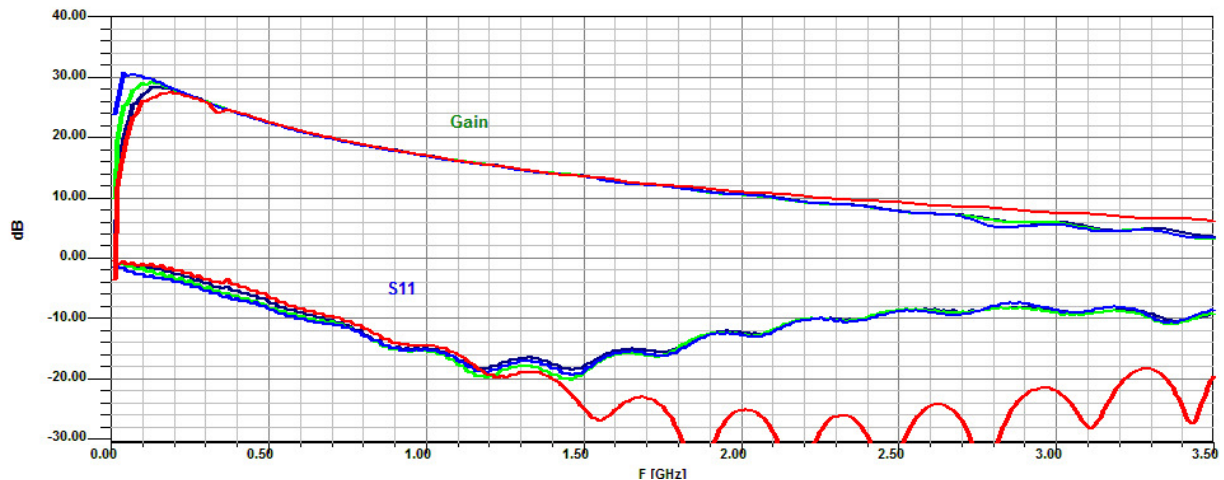

Figure 13 – BGU8051 with different component values

I tried a bit of snowflaking to see if it made a difference. I could easily make the NF worse, so trimming the input line might make it better. The QPL9547 data sheet shows noise parameters with NF of 0.2 dB at 1.3 GHz and 0.18 at 2.3 GHz, a tantalizing prospect for the tweeker. I prefer KISS with the current results.

I also varied the supply voltage on each device. All had best NF around 3.3 volts, close enough to use the 3.3 volt regulators. They are specified for 5 volt operation, and all draw a fair amount of current, around 50 mA, with the data sheet bias resistors, for total of about ¼ watt. This suggests a fairly high IP3 (good intermod performance), but I didn't try to measure it. In any case, a broadband amplifier with high gain is going to need a filter in almost any location.

Packaging

The preamp PC boards are sized to fit on the smallest size Pomona box, shown in Figure 12. I only had a couple on hand, and they are more expensive than the rest of the preamp. The traditional low-cost package for ham products is the Altoids tin. The preamp fits nicely in the small size, shown in Figure 13. While the small ones don't seem common around here, they are quite reasonable in bulk from Amazon. The only problem is the mints – I have a whole jar of them, and I don't eat them.



Figure 14 – Pomona box

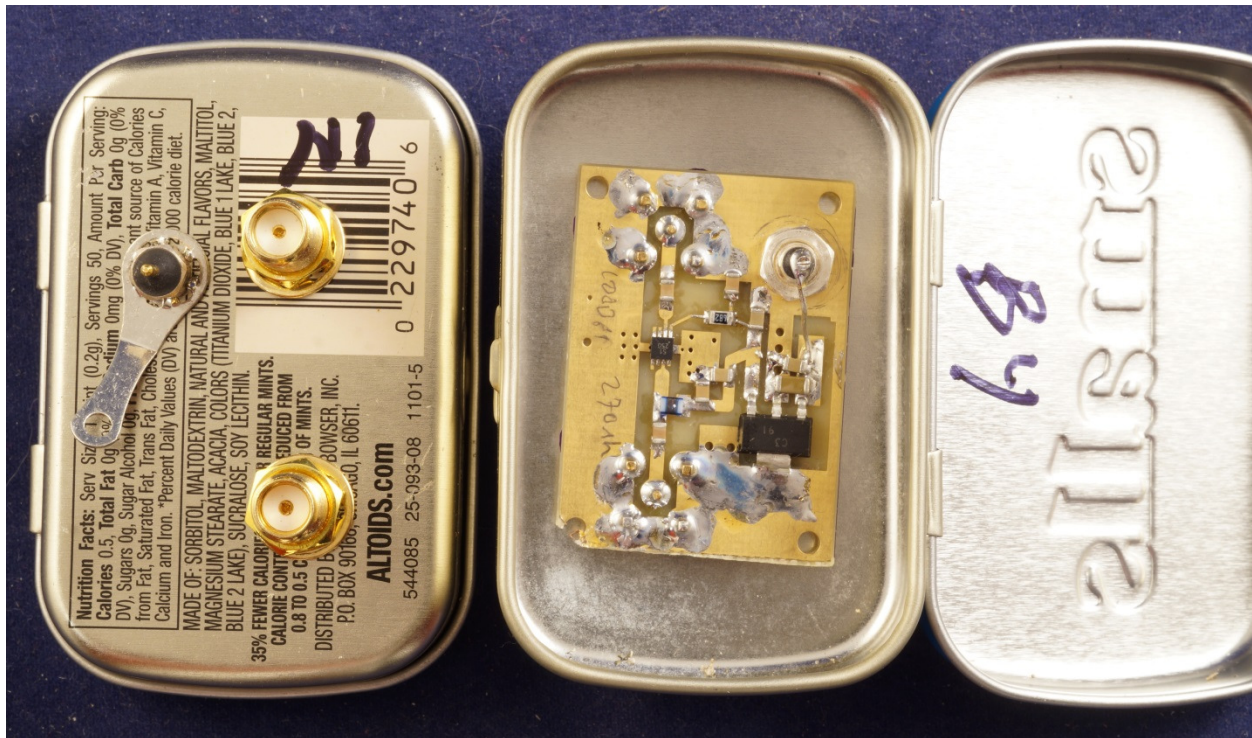

Figure 15 – Preamp in small Altoids box

Summary

The goal of an unconditionally stable low-noise amplifier may be possible. The noise figures are good enough for anything except EME at 1296 and up. The remaining problem is soldering these tiny parts. For most of us, a simple, stable low-noise amplifier with no tuning is very useful.

Which of these devices would I choose? The BGU8051 has excellent performance through 1296 MHz, and cost is about half of the others. The TQP3M9037 has more gain and better performance at higher bands, and doesn't require the bias resistor. And the QPL9547 has the lowest NF potential, if you can find it.

PC boards are available.

The ebay TQP3M9037-LNA module with internal battery looks like a really useful compact LNA, also handy for testing, rover operation, or antenna tests.

Note

1. Mike Seguin, N1JEZ, "Surface Mount Assembly with a Toaster Oven," 47th Eastern VHF/UHF/Microwave Conference (2024), http://www.newsvhf.com/conf2024/PresPapers/N1JEZ-Surface_Mount_Assembly_with_Toaster_Oven.pdf