

# A Flexible VCXO Locking Board

Paul Wade W1GHZ ©2012

[w1ghz@arrl.net](mailto:w1ghz@arrl.net)

Accurate frequency control makes microwave operation much easier. Then you can concentrate on getting the antenna pointed correctly and listening at the right time, instead of tuning the radio hoping to trip over a signal.

Many microwave operators now rely on a GPS-derived frequency reference, so we can expect to find signals within the SSB bandpass before fine-tuning. This is a great improvement – when we first had 10 GHz systems good enough for serious DX work, we discovered that the 10368.100 MHz calling frequency was 25 KHz different between New England and New Jersey. No one knew exact frequency – we just chose one of the more stable stations as a standard.

Recently, N5AC designed the ApolLO synthesizer<sup>1</sup> which generates many ham-specific frequencies from a 10 MHz reference, and made them available through Down East Microwave. These units enable us to have an accurate LO frequency on any of the microwave bands, or an accurate frequency reference for existing rigs.

## GPS 10 MHz Frequency Standards

The first affordable GPS-derived frequency standard was the HP Z3801, when a quantity became available in surplus. These are now scarce, but other units, like the Trimble Thunderbolt, can be found on ebay at fairly reasonable prices. All of them can offer excellent performance, especially after running for a few days, but most require significant power at 28 or 48 volts, so they are best suited for home stations. I've had one running continuously for years as my 10 MHz standard.

For portable operation, we would prefer something smaller that runs on a 12 volt battery and doesn't require a lot of current. It should also lock up quickly to the GPS satellites.

A few years ago, N1JEZ and I copied a design<sup>2</sup> from G3RUH which locked a 10 MHz VCXO to a Rockwell Jupiter GPS engine, with 10KHz output in addition to the more common one pulse per second. The Jupiter GPS engine at that time was available surplus at very reasonable prices, and we made some PC boards available. However, G3RUH has a small business making GPS-disciplined frequency standards and asked us not to make boards with his design. Also, the supply of Jupiter GPS engines seems to have dried up.

The GPS-disciplined 10 MHz oscillator unit available from G3RUH (<http://www.jrmiller.demon.co.uk/>) is an improved version of the design we copied, with a higher quality VCXO. If you prefer to buy a quality turn-key unit, this would be an excellent choice.

## Flexible GPS Frequency Lock

Here is the dilemma – we can lock our frequencies to a 10 MHz reference, but we don't have a source of simple, inexpensive 10 MHz references. I started thinking about a new design, but also about the inconvenience of 10 MHz. While no ham band is a multiple of 10 MHz, almost all VHF and up bands are multiples of 16 MHz, and 16 MHz VCXOs are readily available. Also, my simple transverters have LO chains starting out at 64 or 80 MHz, both multiples of 16 MHz.

The simple GPS frequency reference takes the 10 MHz oscillator output and runs it through a series of decade counters, each dividing the frequency by ten, to produce a 10 KHz output. This is compared with the 10 KHz output from the GPS engine in a phase comparator to produce the control voltage for the VCXO. The same trick works with any combination of two oscillators that produces a common comparison frequency. Locking the 16 MHz VCXO should be trivial – just replace one of the decade counters with a binary counter that divides by 16 to produce 1 MHz, and go from there.

I hacked up one for the last G3RUH boards to see if I could lock a 16 MHz VCXO. The first problem was low output from the 3-volt surface mount VCXO. At 10 MHz, N1JEZ had added a MMIC amp, but that didn't seem to be enough for this unit. Instead, I added a high-speed comparator IC to bring the oscillator output up to 5-volt logic levels. Now only a few millivolts of signal is required, and the 16 MHz VCXO locks right up to a 10 MHz reference, but could also easily lock directly to a 10 KHz GPS engine.

I recently acquired a small frequency counter with a 12 MHz reference oscillator, which could benefit from a more accurate frequency reference. Could I make a more flexible unit? A quick review of the TTL book and the Digikey catalog confirmed that binary counters with presets are still available – these can be configured to divide by any integer from 2 to 16. These can be combined with the decade counters, which don't divide by 10 directly, but rather by 2 and 5, giving us a whole range of possible divisors to cascade. We could even lock up a traditional crystal oscillator by adding a tuning varactor to make it a VCXO – the VCXO doesn't have to be on the PC board.

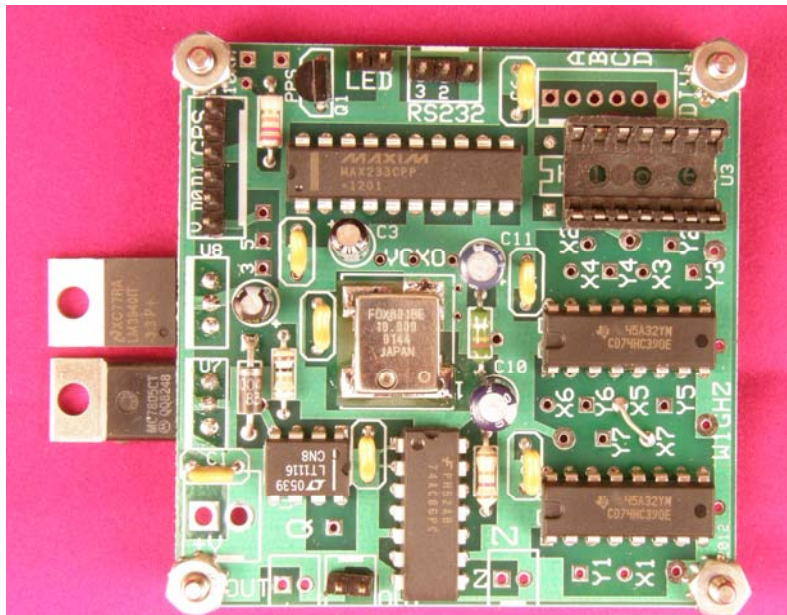

Figure 1 – Flexible VCXO Lock board before adding programming wires

The new design makes all these possibilities available with common ICs by not hard-wiring the dividers on the PCB, but rather making each divider available. Then the dividers are programmed for the desired frequency by wiring them together as needed. We will look at some examples later. Figure 1 is a photo of the basic board with VCXO, before adding the programming wires.

A schematic diagram of the Flexible VCXO lock is shown in Figure 2. Each of the divider inputs is labeled as “Xn” and the corresponding output as “Yn”, with matching labels on the PC board. This allows a simple wiring table – connect Y6 to X7, etc.— which helps me make fewer mistakes.

## GPS Locking

What about a GPS engine? The 10 KHz output is essential – with our simple system, locking to 1 PPS would take far too long and not be very stable. Fortunately, there are some Conaxant GPS engines on ebay with 10 KHz output and reasonable prices. I bought one, and found it satisfactory. There is one minor problem – the default data output is not NMEA, and it takes a command sequence to get it to output NMEA data so we can tell if the unit has a good 3D GPS fix required for accurate frequency output. I hope we can convince W1AUV to make a new version of his 3DFix\_LED PIC<sup>3</sup> for these GPS engines.

The first unit I assembled was for a 10 MHz GPS reference, using the old standard Jupiter GPS engine. This is shown in Figure 3. I’ve had it running my 10 GHz personal beacon for a while. The signal had a bit of warble at first, but settled down to rock-solid after a couple of hours – probably the crystal in the VCXO settling down. More on VCXOs later.

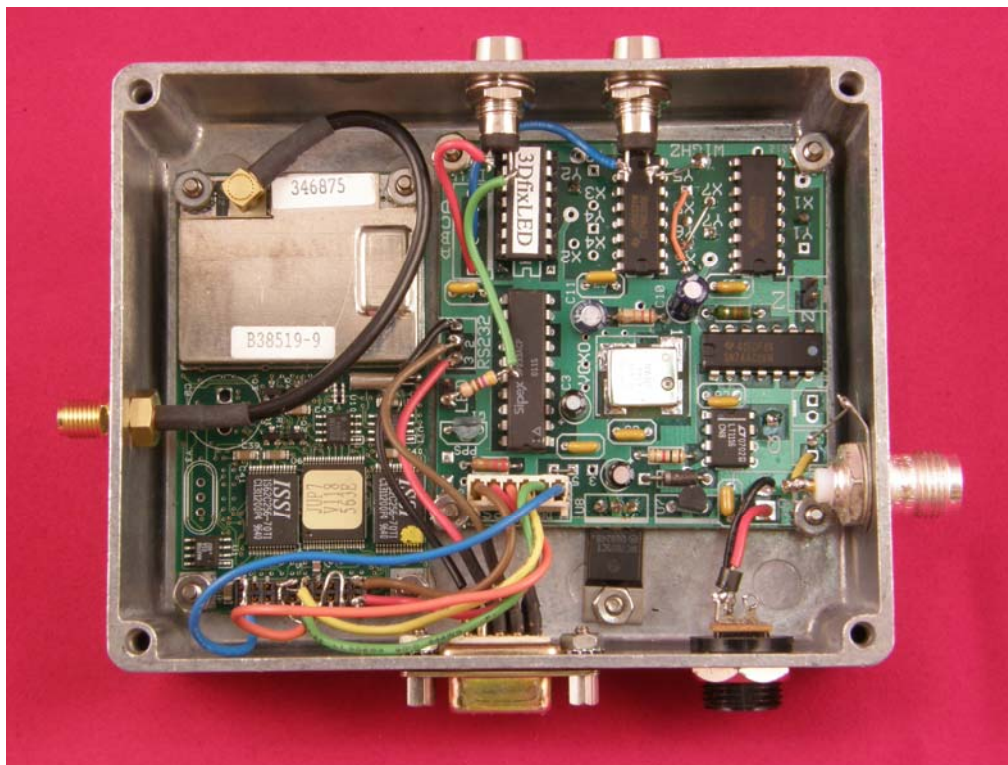

**Figure 3 – 10 MHz VCXO locked to GPS**



Most of the programming wires are on the bottom of the board, shown in Figure 4. A few are on top and can be seen in Figure 3. The choice of top or bottom is totally arbitrary.

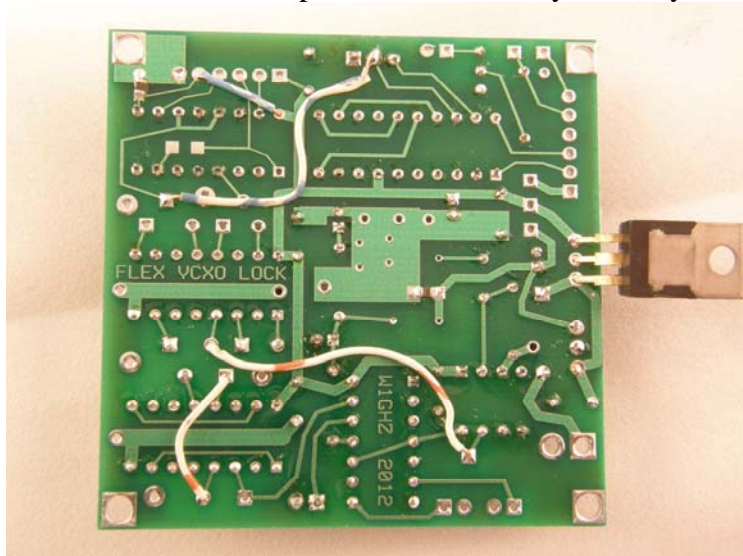
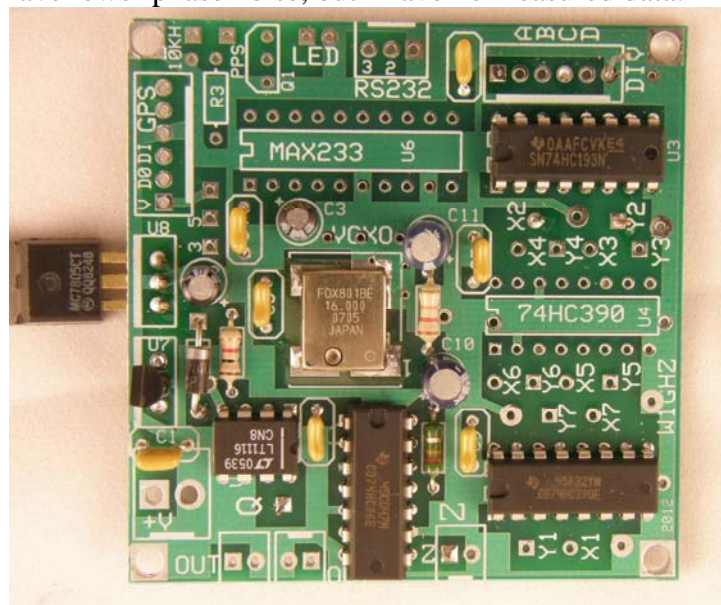

**Figure 4 – Bottom of board with programming wires**

Note that the PC board has positions for three frequency counter ICs, but most applications only use two ICs in some combination. I found that with a little finagling I could put the 3DFix\_LED PIC in the third location, as shown in Figure 3.

### Other Frequencies

Another application is to lock the 16 MHz VCXO to a 10 MHz reference. This version is shown in Figure 5. The 16 MHz is divided down to 1 MHz with a binary counter and the 10 MHz is divided down to 1 MHz with a decade counter. The comparison frequency is then 1 MHz – high comparison frequencies are said to have lower phase noise, but I have no measured data.



**Figure 5 – 16 MHz VCXO locked to 10 MHz reference**

Another variation would be to use the decade counters (there are two in each IC package) to divide the 1 MHz further to 10 KHz and compare it to the 10 KHz GPS engine, locking it directly to GPS.

The same techniques could apply to any VCXO whose frequency is an integral MHz between 1 and 16 MHz, plus even numbers and numbers divisible by 5 up to perhaps 30 MHz.

Another common VCXO frequency is 12.8 MHz. This can be divided by 16, then by 8, to produce 100 KHz. Two decade counters can then divide 10 MHz down to 100 KHz for comparison. But I haven't thought of a use for 12.8 MHz.

## Higher Frequencies

The CMOS ICs I used limit the maximum frequency to somewhere around 30 MHz; they will probably go somewhat faster at room temperature, but portable operation isn't always at comfortable temperatures. The alternative is to use a prescaler chip to divide the frequency down to below 30 MHz. One readily available prescaler will divide by 2, 4 or 8 and works up to at least 1 GHz. One example use would be for a 96 MHz oscillator, found in many microwave LO chains. The prescaler would divide this by 8, to 12 MHz.

The board would be programmed for 12 MHz, and the control voltage fed out to the external 96 MHz oscillator rather than an internal VCXO. The existing oscillator can be easily converted to a VCXO – Down East Microwave provides instructions<sup>4</sup> for their oscillators. Why replace a good, working LO just because it is not exactly on frequency, when you can lock it?

Another possibility is an 80 MHz VCXO I found in the Digikey catalog. This is perfect for my simple 2304 and 3456 transverters. The prescaler would divide by 8, to 10 MHz. This might be my next project – stay tuned.

The goal here is to directly lock a crystal-controlled oscillator for the microwave LO, rather than use an intermediate PLL with a locked 10 MHz reference. A PLL usually uses a VCO with wider tuning range and lower stability, so it must constantly correct the frequency, rather than correcting slowly and gently as we do with the VCXO. The result is that the PLL has higher phase noise. It remains to be seen whether we can make a significant improvement.

How much difference does phase noise make? In side-by-side comparison<sup>5</sup> of PLL and crystal LO at 10.368 GHz during MDS testing, I found the crystal LO yielded about 2 dB better minimum detectable signal. On the other hand, we have seen with MDS tests that knowing the exact frequency can provide up to 5 dB improvement in finding a weak signal. If we can get exact frequency control with lower phase noise, we will have the best of both.

## VCXO

The FOX801BE series VCXO is readily available at 10 and 16 MHz, and provides good performance when multiplied to 10 GHz. Other VCXOs are available in smaller packages, and at lower prices. I designed the board to accommodate all sizes. One smaller one I tried is shown in Figure 6. Multiplied to 10.368 GHz, it had objectionable warble – the signal wandered around a good part of a KHz over a few seconds, but never left the receiver passband.

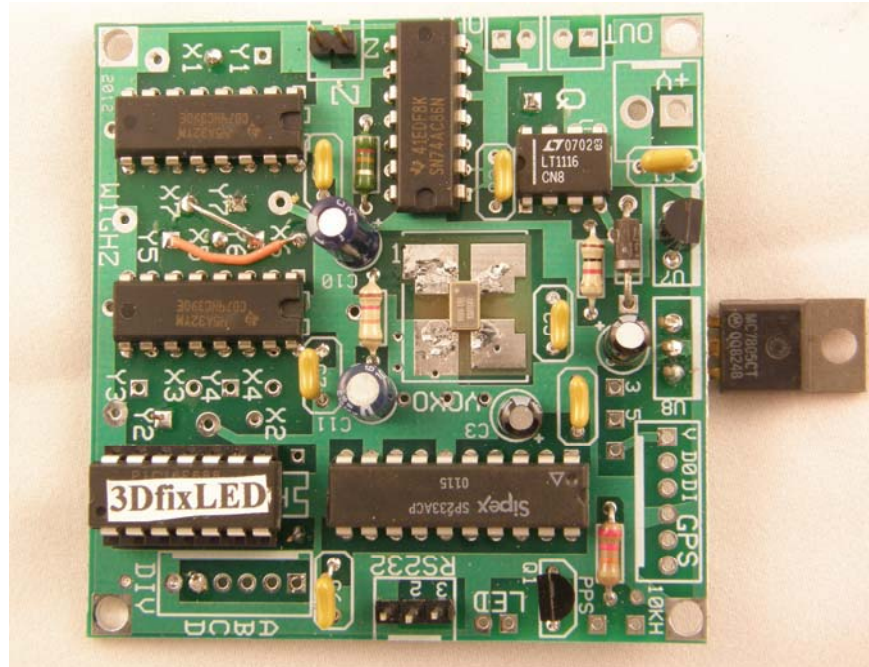

**Figure 6 – Board with smaller VCXO**

The short term stability and phase noise of these oscillators is determined by the crystal quality. The locking circuit has a time constant on the order of 10 seconds – you can see the initial locking on an oscilloscope take nearly a minute. The idea is to gently correct the frequency, but rely on the crystal for stability. Treat it like any other crystal – protect it from shock, vibration, and sudden temperature variations.

The VCXO in Figure 6 stayed in the passband because the average frequency, with locking, is accurate, but the crystal is not good enough to provide short term stability after multiplying into the microwaves. So it would make a lousy LO, but would be good enough for a frequency marker. [Update – KB1VC suggests that the small VCXO has a small internal processor doing temperature compensation. I test this unit wide open, so it may work fine in a closed box, perhaps with a bit of foam over the crystal.]

The surface-mount VCXO units are specified for operation at 3.0 volts  $\pm$  10%. With a 5 volt GPS engine, I use a small 3.0 volt three-terminal regulator at U8 for just the VCXO. For a 3.3 volt GPS engine, a larger 3.3 volt three-terminal regulator at U8 powers both the GPS and the VCXO.

The high-quality GPS units, like the Z3801, have a much higher quality VCXO than these small cans. The oscillator is typically in a heater for greater stability, so the total power required is much greater.

## Programming Examples

### Flexible VCXO Lock Programming Chart

#### Application: 10 MHz Locked to GPS

<u>IC</u>	<u>Divide by</u>	<u>In Freq</u>	<u>Input</u>	<u>From</u>	<u>Out Freq</u>	<u>Output</u>	<u>To</u>
U2	VCXO	-	-	-	10 MHz	Q	X5
U4a	5	10 MHz	X5	Q	2 MHz	Y5	X6
U4a	2	2 MHz	X6	Y5	1 MHz	Y6	X7
U4b	5		X3			Y3	
U4b	2		X4			Y4	
U5a	10	100 KHz	X1	Y7	10 KHz	Y1	U1d
U5b	10	1 MHz	X7	Y6	100 KHz	Y7	X1
U3	(2-16)		X2			Y2	
	A	divisor			-	-	-
	B	divisor			-	-	-
	C	divisor			-	-	-
	D	divisor			-	-	-
U1d	Compare	10 KHz	Z	GPS 10K	-	-	-
	Compare	10 KHz	Y1	hardwired	-	-	-

*leave out U3*

Example 1: this is the original application, locking a 10 MHz VCXO to the 10 KHz output of a GPS engine.

Note that the 74HC390 decade counters do not divide by 10 directly, but rather by 2 and by 5. The output of the divide by two section is a nice symmetrical square wave, while the divide by 5 output is not symmetric. Therefore, it is preferable to do the divide-by-5 first and follow it by the divide-by-2 for a cleaner output. If you trace the connections above on the schematic, you will see that it follows this strategy.



## Programming Examples

### Flexible VCXO Lock Programming Chart

#### Application: 16 MHz locked to GPS

<u>IC</u>	<u>Divide by</u>	<u>In Freq</u>	<u>Input</u>	<u>From</u>	<u>Out Freq</u>	<u>Output</u>	<u>To</u>
U2	VCXO	-	-	-	16 MHz	Q	X2
U4a	5		X5			Y5	
U4a	2		X6			Y6	
U4b	5		X3			Y3	
U4b	2		X4			Y4	
U5a	10	100 KHz	X1	Y7	10 KHz 100	Y1	U1d
U5b	10	1 MHz	X7	Y2	KHz	Y7	X1
U3	16	16 MHz	X2	Q	1 MHz	Y2	X7
	A	divisor	open		-	-	-
	B	divisor	open		-	-	-
	C	divisor	open		-	-	-
	D	divisor	open		-	-	-
	disconnect pin 11						
U1d	Compare	10 KHz	Z	GPS 10K	-	-	-
	Compare	10 KHz	Y1	hardwired	-	-	-

*leave out U4*

Example 2: A 16 MHz VCXO locked to GPS. The difference is that one decade counter is replaced by a 74HC193 binary counter wired for divide-by-16.

## Programming Examples

### Flexible VCXO Lock Programming Chart

#### Application: 16 MHz locked to 10 MHz reference

<u>IC</u>	<u>Divide by</u>	<u>In Freq</u>	<u>Input</u>	<u>From</u>	<u>Out Freq</u>	<u>Output</u>	<u>To</u>
U2	VCXO	-	-	-	16 MHz	Q	X2
U4a	5		X5			Y5	
U4a	2		X6			Y6	
U4b	5		X3			Y3	
U4b	2		X4			Y4	
U5a	10	10 MHz	X1	reference	1 MHz	Y1	U1d
U5b	10		X7			Y7	
U3	16	16 MHz	X2		1 MHz	Q3 (pin7)	Z
	A	divisor	open		-	-	-
	B	divisor	open		-	-	-
	C	divisor	open		-	-	-
	D	divisor	open		-	-	-
disconnect pin 11							
U1d	Compare	1 MHz	Z	U3 pin7	-	-	-
	Compare	1 MHz	Y1	hardwired	-	-	-

*leave out U4*

Example 3: A 16 MHz VCXO is locked to a 10 MHz references, probably originally from GPS. The 10 MHz input goes thru a divide-by-10 while the 16 MHz goes through a divide-by-16 to get both to a 1 MHz compare frequency.

Note that the output of the 74HC193 binary counter is taken from the Q3 output, which is probably more symmetrical, so that both 1 MHz signals are square waves at the comparator.

## Programming Examples

### Flexible VCXO Lock Programming Chart

#### Application: 12 MHz locked to 10 MHz reference

<u>IC</u>	<u>Divide by</u>	<u>In Freq</u>	<u>Input</u>	<u>From</u>	<u>Out Freq</u>	<u>Output</u>	<u>To</u>
U2	VCXO	-	-	-	12MHz	Q	X2
U4a	5		X5			Y5	
U4a	2	10 MHz	X6	reference	5MHz	Y6	X1
U4b	5		X3			Y3	
U4b	2	1 MHz	X4	Y2	0.5 MHz	Y4	Z
U5a	10	5MHz	X1	Y6	0.5 MHz	Y1	U1d
U5b	10		X7			Y7	
U3	12	12 MHz	X2	Q	1 MHz	Y2	X4
	A	divisor	Gnd		-	-	-
	B	divisor	Gnd		-	-	-
	C	divisor	5V		-	-	-
	D	divisor	5V		-	-	-
U1d	Compare	0.5 MHz	Z	Y4	-	-	-
	Compare	0.5 MHz	Y1	hardwired	-	-	-

Example 4: A 12 MHz VCXO is locked to a 10 MHz reference. Now we get tricky – the binary counter is set to divide by 12 by loading a binary 12 (1100) into the ABCD inputs. Each time it counts down to zero, it starts over again at 12.

The output of the binary counter is not symmetrical in this case, so we follow it by divide-by-2 to get a square wave at 0.5 MHz. The 10 MHz reference also goes through a last divide-by-2 to 0.5 MHz to make that the compare frequency. This example uses all three ICs.

For other frequencies, the appropriate binary number is loaded into the ABCD inputs.

## Programming Examples

### Flexible VCXO Lock Programming Chart

#### Application: 5 MHz locked to GPS

<u>IC</u>	<u>Divide by</u>	<u>In Freq</u>	<u>Input</u>	<u>From</u>	<u>Out Freq</u>	<u>Output</u>	<u>To</u>
U2	VCXO	-	-	-	5MHz	Q	X5
U4a	5	5 MHz	X5	Q	1 MHz	Y5	X7
U4a	2		X6			Y6	
U4b	5		X3			Y3	
U4b	2		X4			Y4	
U5a	10	100 KHz	X1	Y7	10 KHz	Y1	U1d
U5b	10	1 MHz	X7	Y6	100 KHz	Y7	X1
U3	(2-16)		X2			Y2	
	A	divisor			-	-	-
	B	divisor			-	-	-
	C	divisor			-	-	-
	D	divisor			-	-	-
U1d	Compare	10 KHz	Z	GPS 10K	-	-	-
	Compare	10 KHz	Y1	hardwired	-	-	-

*leave out U3*

Example 5: 5 MHz oscillator locked to GPS. There are some very good 5 MHz oscillators out there which have been neglected because we could only lock 10 MHz. These can be locked to GPS by simply leaving out one divide-by-2 stage.

## Fix3D\_LED

The 3DFix\_LED PIC from W1AUV detects a 3D fix on the GPS constellation, lighting the LED to tell you that the GPS is ready. After another minute or so, everything should be locked up.

Tommy's schematic of the PIC chip:

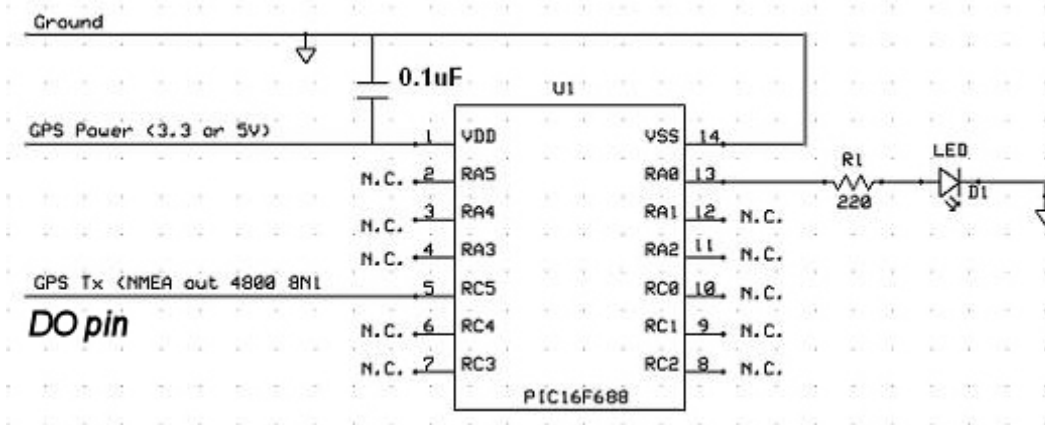

We can fit this in an unused frequency counter position by putting it in backwards, so that pin 14 of the PIC goes in pin 8 of the socket, which is Ground. Then it is a simple matter to run three wires to the remaining pins. The 5V power can be taken from the empty pin 16 of the socket. The resistor and LED are external.

## Summary

This simple unit should enable accurate microwave frequency control with more flexibility, and make for easier contacts with more DX. PC boards are available, and more details and updates may be found at [www.w1ghz.org](http://www.w1ghz.org).

Remember, just because you know exactly where the calling frequency is doesn't mean you have to stay there.

## References

1. Stephen Hicks, N5AC, "A USB Programmable High Stability LO for Microwave Transverters," *Proceedings of the 2008 Southeastern VHF Society Conference*, ARRL, 2008, pp. 220-229.
2. Mike Seguin, N1JEZ, "A Simple GPS Stabilized Oscillator," *Proceedings of Microwave Update 2005*, ARRL 2005, pp. 94-102.
3. Tommy Sullivan, W1AUV, "3Dfix", *Proceedings of Microwave Update 2005*, ARRL 2005, pp. 1-3.
4. "VCXO circuitry for MICRO LO," Design Note DN-020, <http://downeastmicrowave.com/PDF/DN020.PDF>
5. Paul Wade, W1GHZ, "Phase Noise and MDS," *Proceedings of Microwave Update 2009*, ARRL, 2009, pp. 193-196.

## Flexible VCXO Lock Programming Chart

### Application:

<u>IC</u>	<u>Divide by</u>	<u>In Freq</u>	<u>Input</u>	<u>From</u>	<u>Out Freq</u>	<u>Output</u>	<u>To</u>
U2	VCXO	-	-	-		Q	
U4a	5		X5			Y5	
U4a	2		X6			Y6	
U4b	5		X3			Y3	
U4b	2		X4			Y4	
U5a	10		X1			Y1	U1d
U5b	10		X7			Y7	
U3	(2-16)		X2			Y2	
	A	divisor			-	-	-
	B	divisor			-	-	-
	C	divisor			-	-	-
	D	divisor			-	-	-
U1d	Compare		Z		-	-	-
	Compare		Y1	hardwired	-	-	-

Blank programming chart for other applications.